

Connectors M 27



Housings

page 78



Inserts

page 79

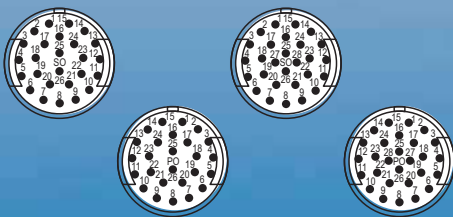

Accessories

page 81





M 23 Signal Connectors

Mechanical Data	Materials and Technical Data
Housing	Copper-Zinc alloy Die Casting
Housing surface	Nickel plated brass other surface upon request
Inserts (for contacts)	Thermoplastic Polyamid PA 6 (Nylon 6/6), PBT Fire protection class V-0
Contacts	Brass Alloy
Contact surface at point of contact	Nickel and gold plated (0,25µm Au)
Minimum mating cycles	> 1000
Seals / O-Rings	Buna-N standard optional Viton® (Viton is a registered trademark of DuPont)
Temperature range	-40° C – 125° C (-40 °F – 257 °F)
Type of contacts	Crimp, solder, dip-solder (PCB)
Protection	IP 67 / IP 69 K per EN 60 529 (connected), NEMA 4x
Cable diameter range	3 – 17 mm (.12 – .55")

Electrical Data			
Number of positions		26	28
Number of contacts		26	28
Contact-Ø [mm]		1	1
Nominal current ¹⁾ [A]		8	8
Nominal voltage ²⁾ [V~]		150	150
Test voltage (Breakdown voltage) ³⁾ [V~]		1500	1500
Isolation resistance [MΩ]		> 10 ¹²	> 10 ¹²
Max. contact resistance [mΩ]		3	3
Degree of Protection ⁴⁾		3	3

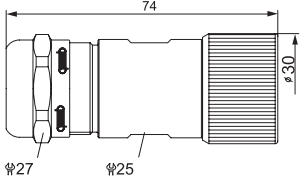
¹⁾, ²⁾, ³⁾, ⁴⁾ See Technical Informations page 14

Straight Connector, Female Thread		Cable-Ø	Part Number
 		7 – 12 mm (.28 - .47")7.110.500.000
		11 – 17 mm (.43 - .67")7.110.600.000
		Contacts and inserts page 79 • Assembly instructions page 83	

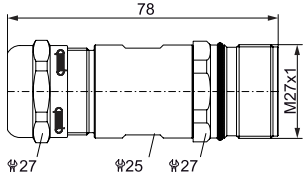
Straight Connector, Male Thread		Cable-Ø	Part Number
 		7 – 12 mm (.28 - .47")7.210.500.000
		11 – 17 mm (.43 - .67")7.210.600.000
		Contacts and inserts page 79 • Assembly instructions page 83	

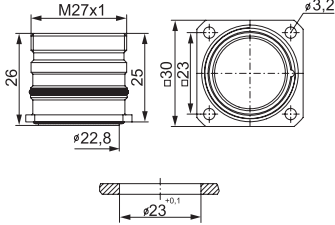

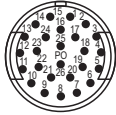
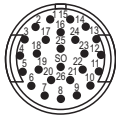
Panel Connector, Male Thread, front mounting		Type	Part Number
 		4 x holes 3,2 mm7.400.700.000
		Contacts and inserts page 79 • Assembly instructions page 84	

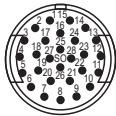



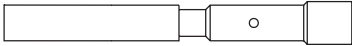

Type	Part Number	Part Number	Inserts 26-pole
Pinout clockwise	Pins	Sockets	
Insert with solder contacts	7.001.926.103	7.001.926.104	 Insert pin mating view
Insert without contacts	7.003.926.101	7.003.926.102	
Insert with dip solder contacts Length 3,5 mm	7.001.926.107		 Insert socket mating view
Insert with dip solder contacts Length 10 mm	7.001.926.127	7.001.926.108	
<p>The correct dimension of a connector with dip solder contacts depends on the particular type of housing.</p>			
Contacts page 80			

Type	Part Number	Part Number	Inserts 28-pole
Pinout clockwise	Pins	Sockets	
Insert with solder contacts	7.001.928.103	7.001.928.104	 Insert pin mating view
Insert with dip solder contacts Length 3,5 mm	7.001.928.107		
Insert with dip solder contacts Length 10 mm	7.001.928.127	7.001.928.108	 Insert socket mating view
<p>The correct dimension of a connector with dip solder contacts depends on the particular type of housing.</p>			
Contacts page 80			

Signal Connectors / required contacts

Contacts	Type	Crimp Range	Part Number
	Crimp pin 1 mm, machined0,14 – 1 mm ² (AWG 26 – 17)7.010.971.001
	Crimp socket 1 mm, machined	...0,14 – 1 mm ² (AWG 26 – 17)7.010.971.002

Contact Arrangement	Number of Poles	Required Contacts
	26	26 x 1 mm
	28	28 x 1 mm

Type	Part Number	Accessories
Plastic protective cap for connectors with male thread7.000.980.167 for connectors with female thread7.000.980.168		
Brass protective cap for connectors with female thread7.010.900.169		
Brass protective cap for connectors with male thread7.010.900.170		
Brass protective cap with chain for connectors with female threadLength 70 mm7.010.9S0.707		
Brass protective cap with chain for connectors with male threadLength 70 mm7.010.9S0.708		
Crimp tool for manual crimping of machined crimp contacts. Works with contacts for power or signal M23.7.000.900.901 See page 96 / 97 for crimp tool instructions and page 82 proper setting		
Assembly tool7.010.900.110		

Connectors M 27 / Assembly Instructions

Crimp Tool Setting for HUMMEL Crimp Contacts (Crimp Tool 7.000.900.901)

Part Number	Crimp Contact	Cross Section mm ²	AWG	Crimp Tool Setting mm	Locator Setting
7.010.971.001	Crimp pin (signal) 1 mm	0,14	26	0,70	1
		0,25	24	0,80	1
		0,34	22	0,88	1
		0,50	20	0,95	1
		0,75	18	1	1
		1	17	1,03	1
7.010.971.002	Crimp socket (signal) 1 mm	0,14	26	0,70	4
		0,25	24	0,80	4
		0,34	22	0,88	4
		0,50	20	0,95	4
		0,75	18	1	4
		1	17	1,03	4

These values are only guidelines and actual conductor cross sections depend on manufacturer tolerances.

Straight Connector, Female Thread

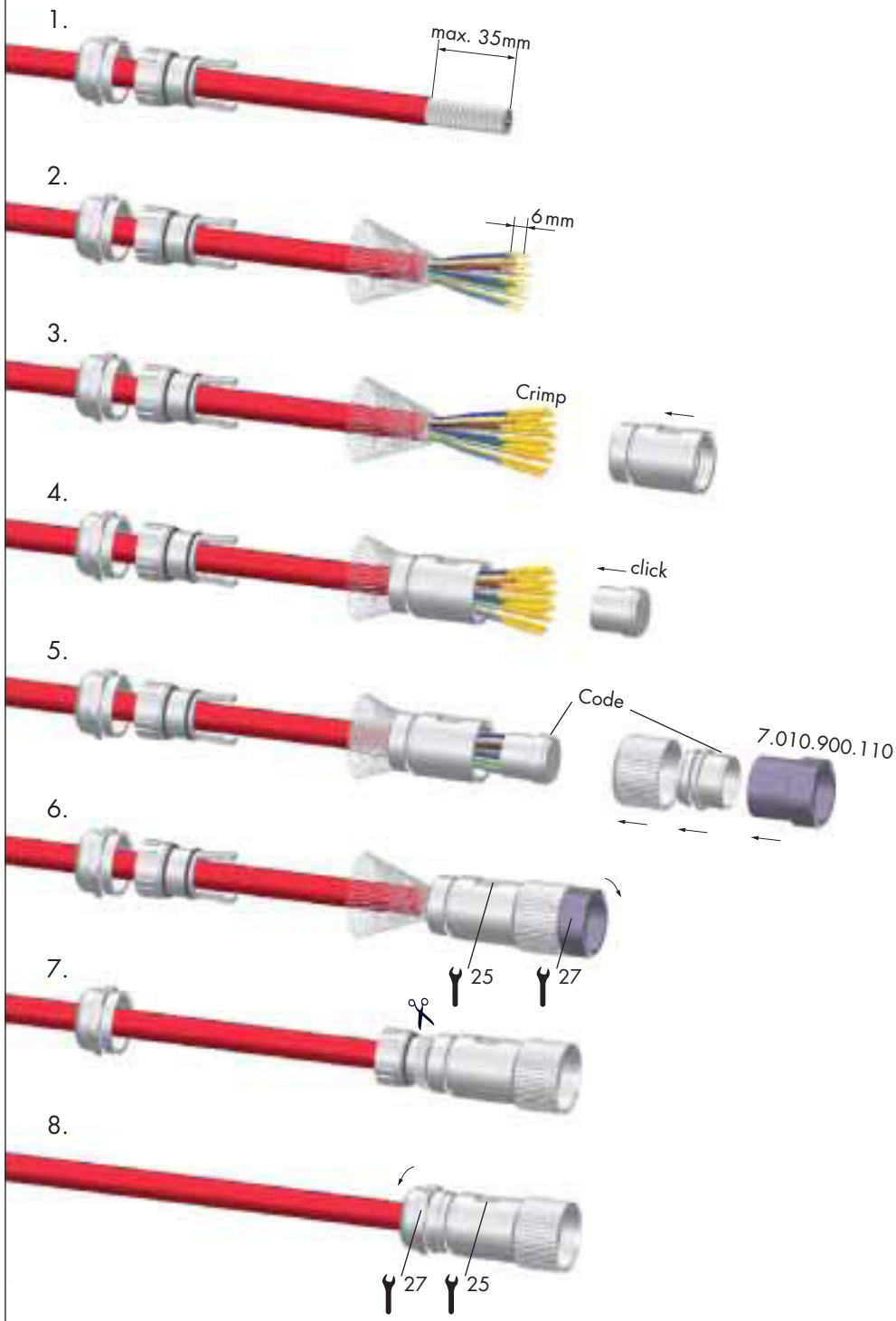

Panel Connector

